

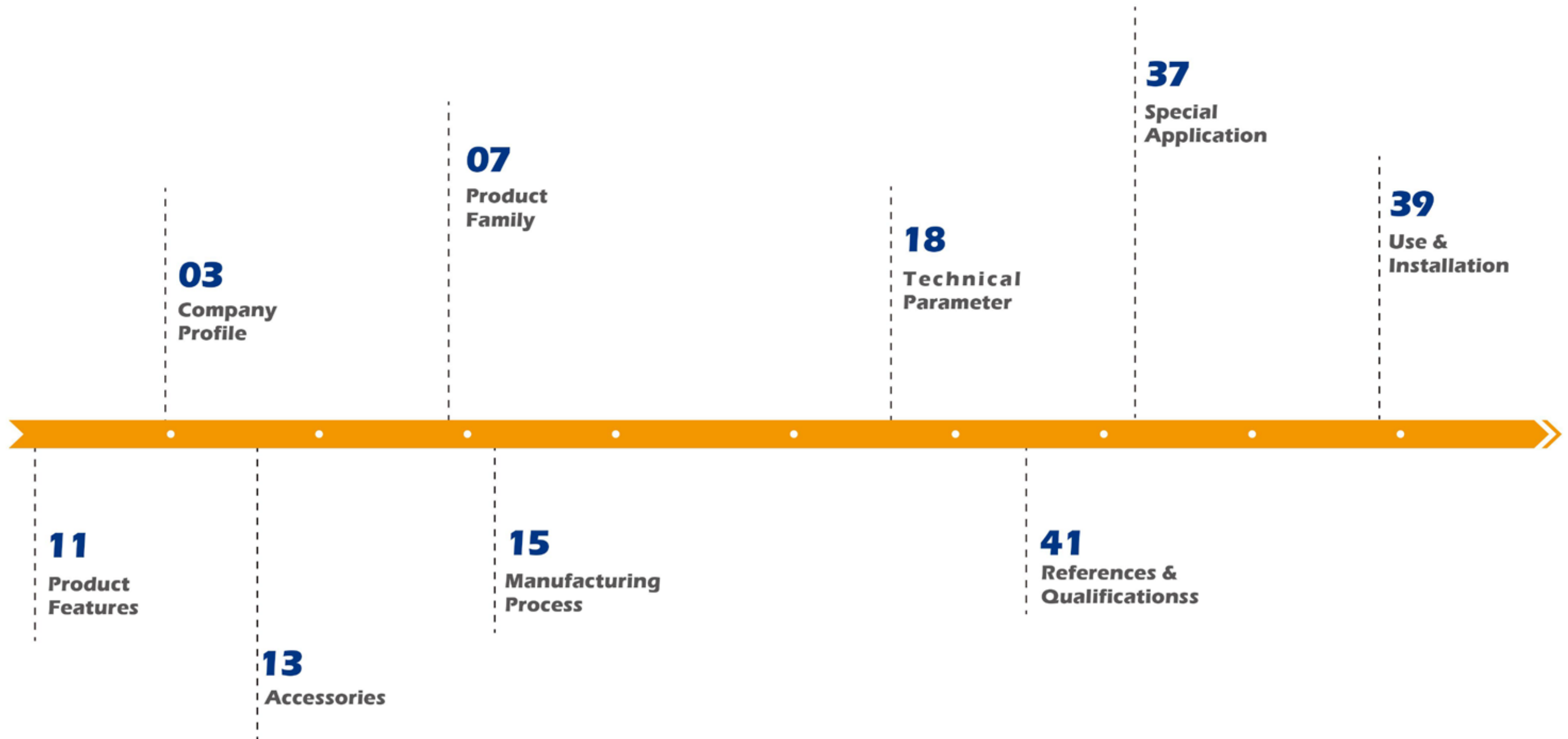

# CAST RESIN TRANSFORMER

Precision Crafted Perfect Quality







# COMPANY PROFILE

# 1



# 为世界输出优质动力

## Delivering Premium Power To The World



### 1990 Year of establishment

Founded in 1990, CEEG has been focusing on manufacturing for 30 years and exporting quality power equipment to the world with the core values of "Vision, Innovation and Responsibility". So far, CEEG has three major industries: power transmission and distribution, new energy and system solutions, with industrial bases in Nanjing and Yangzhong.

CEEG was successively awarded the honorary titles of National Innovative Enterprise, Top 500 Asian Brands, Most Influential Brand of China Electrical Industry, China Environmental Label, and National Contract-observing and Creditable Enterprise.



## Delivering Premium Power To The World

- ▶ FORESIGHT
- ▶ INNOVATION
- ▶ RESPONSIBILITY

China Electric Equipment (Jiangsu) Transformer Manufacture Co., Ltd. is a modern enterprise integrating manufacturing, sales and scientific research. It has a complete set of shearing machines, automatic wrapping machine, robotic automatic laminating machine, German Hedrich vacuum casting tank, vacuum impregnation, electric transfer vehicle and other advanced equipments representing a high level in the industry, and is the first in the industry to develop and apply transformer collaborative design platform to effectively combine product data, product development and production process. CEEG's products include VPI transformer, cast resin transformer, semi-envelope transformer, oil-immersed transformers, traction transformers, 220kV power transformers, 110kV power transformer, mining explosion-proof transformer, mining explosion-proof switches, high and low voltage switchgear, frequency conversion transformer, amorphous alloy transformer, anti-harmonic transformer, Scott transformer, substation, wind power transformer, marine transformer, etc. Its sales cover many industries such as electric power, electronics, hydropower, nuclear power, wind power, coal mines, communications, construction, petroleum, chemical industry, aviation, transportation, railroad, etc.

Walking with giants and keeping pace with the world. CEEG has established long-term strategic partnerships with world-class companies such as DuPont, Schneider, DSI. Pursuing innovation, fulfilling responsibilities, and constantly surpassing products, quality, services and actions, it has developed into a domestic giant power transmission and distribution equipment supplier with a solid industrial foundation. Its cast resin dry type transformers have been exported to more than 40 countries and regions in the world.





# 2

## PRODUCT FAMILY



01	02	03
04	05	06
07	08	09

1. Amorphous Metal Transformer

2. VPI Transformer

3. Cast Resin Transformer

4. 220kV Power Transformer

5. 220kV Traction Transformer

6. 110kV Traction Transformer

7. 110kV Power Transformer

8. Auto Transformer

9. 110kV Mobile Transformer



- 1. 35kV Power Transformer
- 2. 20kV Transformer
- 3. 11kV Distribution Transformer
- 4. 35kV Cast Resin Transformer
- 5. 35kV Traction Transformer
- 6. 11kV Traction Transformer
- 7. Harmonic Mitigating Transformer
- 8. Substation
- 9. Substation



- 1. Mining HV Switchgear
- 2. Mining Flame-proof Substation
- 3. Mining LV Switchgear
- 4. Rectifier Transformer
- 5. Ocean Platform Transformer
- 6. Marine Transformer
- 7. AFWF Transformer
- 8. Integrated PV Step-up Transformer
- 9. New Energy Substation





# 3

## PRODUCT FEATURES



**10kV Transformer**

1. Low loss, low partial discharge and low noise;
2. The product performance parameters of SCB11, SCB12 and SCB13 series are better than GB and IEC standards;
3. It is safe, flame-retardant, fireproof and pollution-free, and can be directly installed in the load center;
4. Maintenance free, convenient installation and low comprehensive operation cost;
5. Low temperature rise and high product reliability;
6. Stable structure and strong seismic capacity;
7. Moisture proof, corrosion-resistant, wide application range.



**35kV Transformer**

1. Through the dynamic thermal stability simulation analysis, the winding structure is reasonably arranged and has strong short-circuit resistance;
2. Low loss, low noise and low partial discharge;
3. It can also operate under overload for a long time without air cooling, with strong overload capacity;
4. Winding capacitance distribution is reasonable and impact resistance is strong;
5. The product has the characteristics of flame retardant and self extinguishing, non-toxic and harmful gas generation, green and environmental protection.



**Traction Rectifier Transformer**

1. Low temperature rise, strong overload capacity and reliable operation under class VI load conditions
2. The key technical parameters are well balanced, the load is evenly distributed, and the amount of non characteristic harmonics is effectively reduced.
3. The coil adopts axial double split structure, which can eliminate the balance reactor and smooth the output DC waveform.
4. High mechanical strength, good moisture resistance, partial discharge  $\leq 10\text{pc}$ .
5. Low noise and electromagnetic radiation pollution.



# 4

## ACCESSORIES

### + Enclosure

The enclosure can be divided into indoor type and outdoor type. There are several observation windows on the enclosure, and the enclosure can be sprayed with the color of the user's choice.

The degree of protection of the enclosure is generally divided into IP20 or IP23. IP20 prevents the ingress of solid foreign objects larger than 12 mm and protects against accidental shocks. In addition to the functions of IP20, IP23 can also prevent water drops from entering within 60 degrees from the vertical, which is suitable for outdoor installation.

The material of the enclosure is divided into ordinary steel sheet, plastic injection molding, stainless steel sheet, aluminum alloy composite sheet, etc.



### + Temperature Controller

All transformers are equipped with an overheating protection device. The overheat protection device detects and controls the temperature of the transformer by means of a PT thermistor built into the low voltage coil and outputs a digital signal via the RS232 / 485 communication interface. The device provides the following functions:

1. during the operation of the transformer, the temperature value of the three-phase winding is displayed on a circuit.
2. display of the temperature value of the hottest phase winding.
3. overtemperature alarm and overtemperature shutdown.
4. audible and visual alarm and fan start.



### + Air Cooling Device

The cooling mode of dry type transformer is divided into natural air cooling (AN) and forced air cooling (AF).

Natural air cooling (AN) can continuously provide 120% of the rated power under normal operating conditions.

Forced air cooling (AF) can increase the capacity by 50% under normal operating conditions, which is suitable for all types of emergency overloads or intermittent overload operation. Due to the large increase in load losses and impedance resistance, forced air cooling (AF) is generally not recommended for long-term continuous overload operation.



### + Copper Bar

1. in general, the incoming and outgoing modes of the cables are divided into: upper incoming & outgoing, lower incoming & outgoing, side incoming & outgoing.

2. for transformer with rated power  $\leq 200\text{KVA}$ , the conventional outgoing mode is still used, and the side outgoing line is connected by the user with a cable.

3. if the rated power is  $\geq 1600\text{KVA}$ , a, b, and c use double-row feeder lines with a spacing of 10 (1600/200kva) or 12 (2500kva).

4. since the zero line is at the top of the transformer, it is recommended that the transformer zero line still enters the switchgear from the top if the zero line is brought out from the bottom of the switchgear.





# MANUFACTURING PROCESS

5

## MANUFACTURING PROCESS



The high-voltage winding conductor is wound with high-quality conductor and reinforced with long and short cut glass fiber felt. It is poured by the world's most advanced Heidrich vacuum pouring system under vacuum. Effectively restrain the occurrence of partial discharge, and the partial discharge is  $\leq 5\text{pc}$ .



The low-voltage winding adopts high-quality foil conductor and is wound on an automatic foil winding machine. The foil winding machine adopts the patented technology of "foil wire hydraulic energy-saving tension crimping device", high-precision detection of  $\pm 0.5\text{mm}$  and advanced argon arc welding technology, which plays a key role in ensuring the quality of coil winding.



The iron core adopts high-quality high magnetic conductivity oriented silicon steel sheet, 45° full oblique step lapping process, and the surface adopts special moisture-proof and rust proof coating, which effectively reduces the no-load loss, no-load current and noise level.

## DESIGN

Based on more than 30 years of design, manufacturing and experimental experience in the transformer industry, CEEG has developed a set of advanced "three-dimensional + parametric" design software, which can realize automatic design, cost optimization and simulation. Fully considering the requirements of the national and industrial standards, ensuring the advanced design of products.

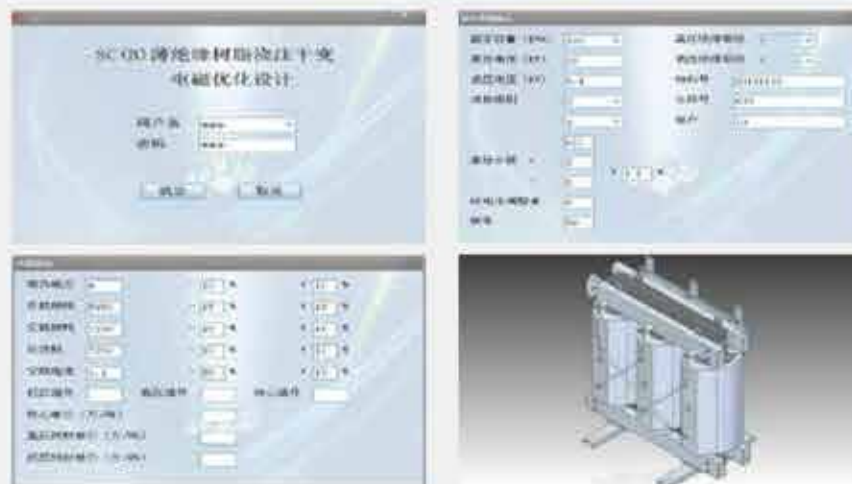



TESTING



All products strictly control the production process and quality links, and conduct strict test and inspection according to national standards and customer customized requirements before leaving the factory, including partial discharge inspection, lightning resistance and electric shock inspection, noise inspection and other necessary inspection items. Advanced test and detection equipment and perfect inspection and detection system ensure the high quality and high quality of products.



6

TECHNICAL  
PARAMETER



### SC(B) 10-100~2500/10

HV: 10 (10.5,11,6.6,6.3,6)kV  
 LV: 0.4kV  
 Vector Group: Dyn11, Yyn0  
 Tapping Range:  $\pm 2 \times 2.5\%$

Model	Uk %	P0 (W)	Pk (75°) (W)	I0%	LPA(AN)dB	Gauge m x n (mm)	Transformer Dimension LxBxH (mm)	Enclosure Size (top outging line) (footing included)	Enclosure Size (side outging line) (footing included)
SC (B) 10-100/10	4	400	1371	0.7	42	550×550	960×750×804	1700×1400×1600	1700×1400×2200
SC (B) 10-125/10	4	470	1616	0.7	43	550×550	960×750×804	1700×1400×1600	1700×1400×2200
SC (B) 10-160/10	4	540	1860	0.7	43	550×550	1040×750×859	1700×1400×1600	1700×1400×2200
SC (B) 10-200/10	4	620	2209	0.7	43	550×550	1040×750×874	1700×1400×1600	1700×1400×2200
SC (B) 10-250/10	4	720	2410	0.7	43	660×660	1090×860×856	1700×1400×1600	1700×1400×2200
SC (B) 10-315/10	4	880	3030	0.7	45	660×660	1100×860×923	1700×1400×1600	1700×1400×2200
SC (B) 10-400/10	4	980	3484	0.7	45	660×660	1120×860×913	1700×1400×1600	1700×1400×2200
SC (B) 10-500/10	4	1160	4260	0.6	46	660×660	1240×860×953	1700×1400×1600	1700×1400×2200
SC (B) 10-630/10	4	1340	5134	0.6	46	820×660	1360×860×956	1900×1500×1800	1900×1500×2200
SC (B) 10-630/10	6	1300	5200	0.6	48	820×660	1380×860×938	1900×1500×1800	1900×1500×2200
SC (B) 10-800/10	6	1520	6020	0.5	49	820×820	1450×1020×993	1900×1500×1800	1900×1500×2200
SC (B) 10-1000/10	6	1770	7090	0.4	50	820×820	1510×1020×1058	1900×1500×1800	1900×1500×2200
SC (B) 10-1250/10	6	2090	8460	0.4	51	820×820	1530×1020×1140	1900×1600×1800	1900×1600×2200
SC (B) 10-1600/10	6	2450	10240	0.3	51	820×1070	1560×1150×1223	2000×1600×2000	2000×1600×2200
SC (B) 10-2000/10	6	3050	12600	0.3	52	1070×1070	1580×1150×1273	2000×1600×2000	2000×1600×2200
SC (B) 10-2500/10	6	3600	15000	0.3	53	1070×1070	1700×1150×1383	2200×1600×2200	2200×1600×2200
SC (B) 10-1600/10	8	2450	11263	0.3	51	820×1070	1590×1150×1198	2000×1600×2000	2000×1600×2200
SC (B) 10-2000/10	8	3050	13882	0.3	52	1070×1070	1660×1150×1298	2000×1600×2000	2000×1600×2200
SC (B) 10-2500/10	8	3600	16414	0.3	53	1070×1070	1720×1150×1493	2200×1600×2200	2200×1600×2200

Note: The data given in this manual is for planning and selection purposes only. Final data may vary.

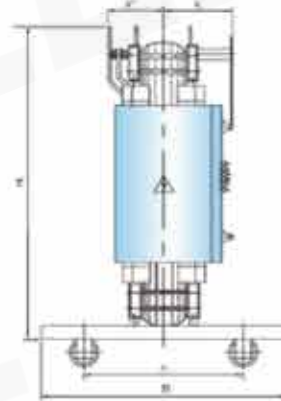
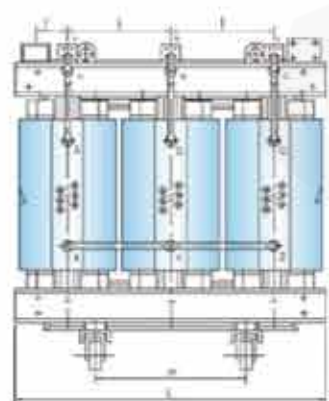

LV Terminal Busbar

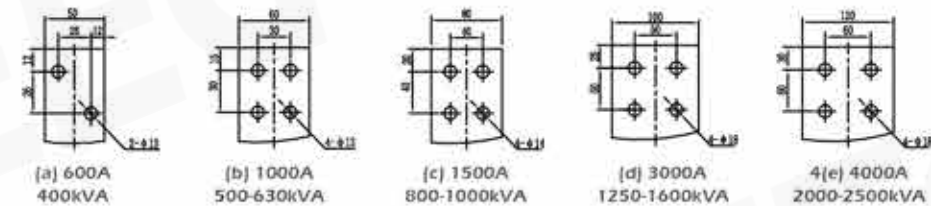



### SC(B) 11-100~2500/10

HV: 10 (10.5,11,6.6,6.3,6)kV  
 LV: 0.4kV  
 Vector Group: Dyn11, Yyn0  
 Tapping Range:  $\pm 2 \times 2.5\%$

Model	Uk %	PO (W)	Pk (75°) (W)	I0%	LPA(AN)dB	Gauge m x n (mm)	Transformer Dimension LxBxH (mm)	Enclosure Size (top outgoing line) (footing included)	Enclosure Size (side outgoing line) (footing included)
SC (B) 11-100/10	4	360	1371	0.7	42	550×550	960×750×804	1700×1400×1600	1700×1400×2200
SC (B) 11-125/10	4	423	1616	0.7	43	550×550	960×750×804	1700×1400×1600	1700×1400×2200
SC (B) 11-160/10	4	486	1860	0.7	43	550×550	1040×750×859	1700×1400×1600	1700×1400×2200
SC (B) 11-200/10	4	558	2209	0.7	43	550×550	1040×750×874	1700×1400×1600	1700×1400×2200
SC (B) 11-250/10	4	648	2410	0.7	43	660×660	1090×860×856	1700×1400×1600	1700×1400×2200
SC (B) 11-315/10	4	792	3030	0.7	45	660×660	1100×860×923	1700×1400×1600	1700×1400×2200
SC (B) 11-400/10	4	882	3484	0.7	45	660×660	1120×860×913	1700×1400×1600	1700×1400×2200
SC (B) 11-500/10	4	1044	4260	0.6	46	660×660	1240×860×953	1700×1400×1600	1700×1400×2200
SC (B) 11-630/10	4	1206	5134	0.6	46	820×660	1360×860×956	1900×1500×1800	1900×1500×2200
SC (B) 11-630/10	6	1170	5200	0.6	48	820×660	1380×860×938	1900×1500×1800	1900×1500×2200
SC (B) 11-800/10	6	1368	6020	0.5	49	820×820	1450×1020×993	1900×1500×1800	1900×1500×2200
SC (B) 11-1000/10	6	1593	7090	0.4	50	820×820	1510×1020×1058	1900×1500×1800	1900×1500×2200
SC (B) 11-1250/10	6	1881	8460	0.4	51	820×820	1530×1020×1140	1900×1600×1800	1900×1600×2200
SC (B) 11-1600/10	6	2205	10240	0.3	51	820×1070	1560×1150×1223	2000×1600×2000	2000×1600×2200
SC (B) 11-2000/10	6	2745	12600	0.3	52	1070×1070	1580×1150×1273	2000×1600×2000	2000×1600×2200
SC (B) 11-2500/10	6	3240	15000	0.3	53	1070×1070	1700×1150×1383	2200×1600×2200	2200×1600×2200
SC (B) 11-1600/10	8	2205	11263	0.3	51	820×1070	1590×1150×1198	2000×1600×2000	2000×1600×2200
SC (B) 11-2000/10	8	2745	13882	0.3	52	1070×1070	1660×1150×1298	2000×1600×2000	2000×1600×2200
SC (B) 11-2500/10	8	3240	16414	0.3	53	1070×1070	1720×1150×1493	2200×1600×2200	2200×1600×2200

Note: The data given in this manual is for planning and selection purposes only. Final data may vary.

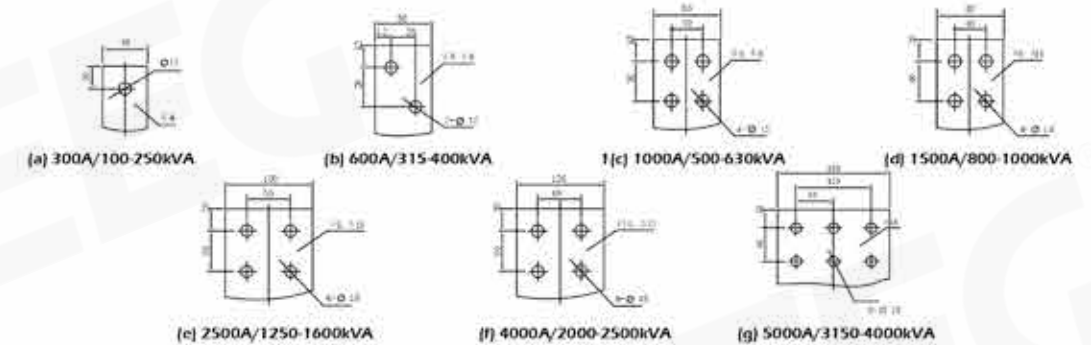
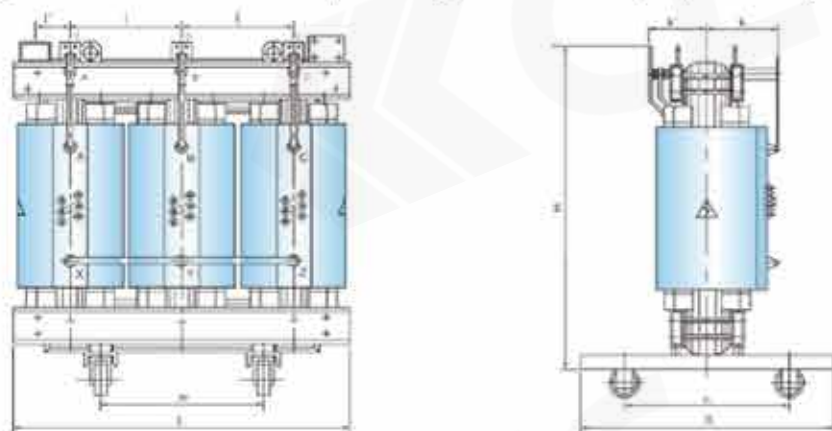

LV Terminal Busbar



**SC(B) 12-100~2500/10**HV: 10 (10.5,11,6.6,6.3,6)kV  
LV: 0.4kVVector Group: Dyn11, Yyn0  
Tapping Range:  $\pm 2 \times 2.5\%$ 

Model	Uk %	P0 (W)	Pk (75°) (W)	I0%	LPA(AN)dB	Gauge m x n (mm)	Transformer Dimension LxBxH (mm)	Enclosure Size (top outging line) (footing included)	Enclosure Size (side outging line) (footing included)
SC (B) 12-100/10	4	320	1371	0.7	42	550×550	970×750×810	1700×1400×1600	1700×1400×2200
SC (B) 12-125/10	4	375	1616	0.7	43	550×550	970×750×810	1700×1400×1600	1700×1400×2200
SC (B) 12-160/10	4	430	1860	0.7	43	550×550	1050×750×860	1700×1400×1600	1700×1400×2200
SC (B) 12-200/10	4	495	2209	0.7	43	550×550	1060×750×880	1700×1400×1600	1700×1400×2200
SC (B) 12-250/10	4	575	2410	0.7	43	660×660	1000×860×950	1700×1400×1600	1700×1400×2200
SC (B) 12-315/10	4	705	3030	0.7	45	660×660	1030×860×996	1700×1400×1600	1700×1400×2200
SC (B) 12-400/10	4	785	3485	0.7	45	660×660	1050×860×1041	1700×1400×1600	1700×1400×2200
SC (B) 12-500/10	4	930	4261	0.6	46	660×660	1090×860×1190	1700×1400×1600	1700×1400×2200
SC (B) 12-630/10	4	1070	5135	0.6	46	820×660	1170×860×1256	1900×1500×1800	1900×1500×2200
SC (B) 12-630/10	6	1040	5205	0.6	48	820×660	1210×860×1123	1900×1500×1800	1900×1500×2200
SC (B) 12-800/10	6	1215	6080	0.5	49	820×820	1230×1020×1161	1900×1500×1800	1900×1500×2200
SC (B) 12-1000/10	6	1415	7098	0.4	50	820×820	1320×1020×1274	1900×1500×1800	1900×1500×2200
SC (B) 12-1250/10	6	1670	8460	0.4	51	820×820	1420×1020×1133	1900×1600×1800	1900×1600×2200
SC (B) 12-1600/10	6	1960	10241	0.3	51	820×1070	1490×1150×1398	2000×1600×2000	2000×1600×2200
SC (B) 12-2000/10	6	2440	12616	0.3	52	1070×1070	1500×1150×1408	2000×1600×2000	2000×1600×2200
SC (B) 12-2500/10	6	2880	14990	0.3	53	1070×1070	1570×1150×1483	2200×1600×2200	2200×1600×2200
SC (B) 12-1600/10	8	1960	11263	0.3	51	820×1070	1530×1150×1350	2000×1600×2000	2000×1600×2200
SC (B) 12-2000/10	8	2440	13882	0.3	52	1070×1070	1610×1150×1416	2000×1600×2000	2000×1600×2200
SC (B) 12-2500/10	8	2880	16414	0.3	53	1070×1070	1720×1150×1508	2200×1600×2200	2200×1600×2200

Note: The data given in this manual is for planning and selection purposes only. Final data may vary.



**SC(B) 13-100 ~ 2500/10**

HV: 10 (10.5,11,6.6,6.3,6)kV  
LV: 0.4kV

Vector Group: Dyn11, Yyn0  
Tapping Range:  $\pm 2 \times 2.5\%$

Model	Uk %	P0 (W)	Pk (75°) (W)	I0%	LPA(AN)dB	Gauge m x n (mm)	Transformer Dimension LxBxH (mm)	Enclosure Size (top outgoing line) (footing included)	Enclosure Size (side outgoing line) (footing included)
SC (B) 13-100/10	4	290	1236	0.7	42	550×550	990×750×790	1700×1400×1600	1700×1400×2200
SC (B) 13-125/10	4	340	1454	0.7	43	550×550	990×750×830	1700×1400×1600	1700×1400×2200
SC (B) 13-160/10	4	385	1672	0.7	43	550×550	1060×750×880	1700×1400×1600	1700×1400×2200
SC (B) 13-200/10	4	445	1990	0.7	43	660×660	980×860×900	1700×1400×1600	1700×1400×2200
SC (B) 13-250/10	4	515	2170	0.7	43	660×660	1000×860×920.5	1700×1400×1600	1700×1400×2200
SC (B) 13-315/10	4	635	2730	0.7	45	660×660	1030×860×996	1700×1400×1600	1700×1400×2200
SC (B) 13-400/10	4	705	3135	0.7	45	660×660	1060×860×1038	1700×1400×1600	1700×1400×2200
SC (B) 13-500/10	4	835	3835	0.6	46	660×660	1120×860×1180	1700×1400×1600	1700×1400×2200
SC (B) 13-630/10	4	965	4620	0.6	46	820×660	1170×860×1256	1900×1500×1800	1900×1500×2200
SC (B) 13-630/10	6	935	4685	0.6	48	820×660	1210×860×1103	1900×1500×1800	1900×1500×2200
SC (B) 13-800/10	6	1095	5470	0.5	49	820×820	1230×1020×1161	1900×1500×1800	1900×1500×2200
SC (B) 13-1000/10	6	1275	6390	0.4	50	820×820	1320×1020×1274	1900×1500×1800	1900×1500×2200
SC (B) 13-1250/10	6	1505	7615	0.4	51	820×820	1350×1020×1353	1900×1600×1800	1900×1600×2200
SC (B) 13-1600/10	6	1765	9216	0.3	51	820×1070	1390×1150×1373	2000×1600×2000	2000×1600×2200
SC (B) 13-2000/10	6	2195	11355	0.3	52	1070×1070	1500×1150×1426	2000×1600×2000	2000×1600×2200
SC (B) 13-2500/10	6	2590	13500	0.3	53	1070×1070	1570×1150×1483	2200×1600×2200	2200×1600×2200
SC (B) 13-1600/10	8	1715	10137	0.3	51	820×1070	1610×1150×1273	2000×1600×2000	2000×1600×2200
SC (B) 13-2000/10	8	2135	12494	0.3	52	1070×1070	1610×1150×1416	2000×1600×2000	2000×1600×2200
SC (B) 13-2500/10	8	2520	14773	0.3	53	1070×1070	1610×1150×1563	2200×1600×2200	2200×1600×2200

Note: The data given in this manual is for planning and selection purposes only. Final data may vary.

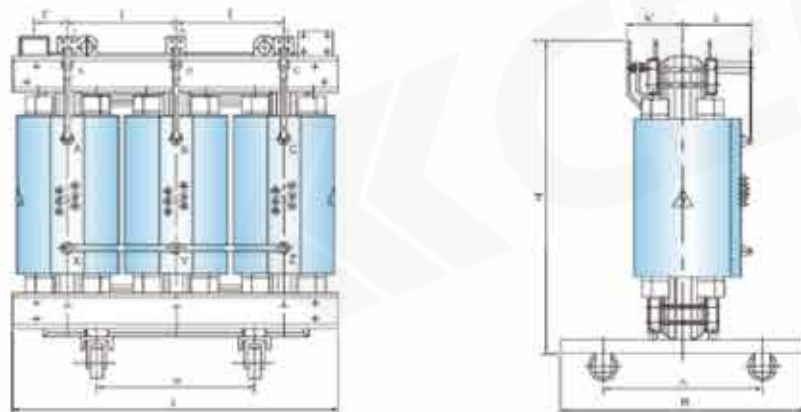

LV Terminal Busbar

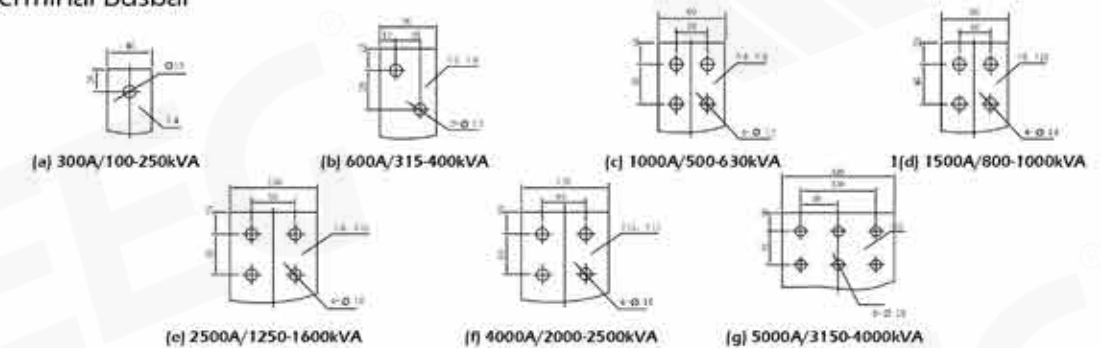



**SC(B)14-100~2500/10**HV: 10 (10.5,11,6.6,6.3,6)kV  
LV: 0.4kVVector Group: Dyn11, Yyn0  
Tapping Range:  $\pm 2 \times 2.5\%$ 

Model	Uk %	P0 (W)	Pk (75°) (W)	I0%	LPA(AN)dB	L×B×H(mm)	Gauge m x n (mm)	Enclosure Size (top outging line) (footing included)	Enclosure Size (side outging line) (footing included)
SC(B)14-100/10	4	270	1240	0.7	42	1050×750×790	550×550	1700×1400×1600	1700×1400×2200
SC(B)14-125/10	4	320	1450	0.7	42	1050×750×830	550×550	1700×1400×1600	1700×1400×2200
SC(B)14-160/10	4	365	1670	0.7	42	1100×750×880	550×550	1700×1400×1600	1700×1400×2200
SC(B)14-200/10	4	420	1990	0.7	43	1090×750×900	550×550	1700×1400×1600	1700×1400×2200
SC(B)14-250/10	4	490	2170	0.7	43	1150×860×940	660×660	1700×1400×1600	1700×1400×2200
SC(B)14-315/10	4	600	2730	0.7	45	1180×860×970	660×660	1700×1400×1600	1700×1400×2200
SC(B)14-400/10	4	665	3140	0.7	45	1290×860×990	660×660	1700×1400×1600	1700×1400×2200
SC(B)14-500/10	4	790	3830	0.6	46	1260×860×1030	660×660	1700×1400×1600	1700×1400×2200
SC(B)14-630/10	4	910	4610	0.6	46	1300×860×1120	820×660	1900×1500×1800	1900×1500×2200
SC(B)14-630/10	6	885	4690	0.6	46	1390×860×1060	820×660	1900×1500×1800	1900×1500×2200
SC(B)14-800/10	6	1035	5470	0.4	49	1450×1020×1070	820×820	1900×1500×1800	1900×1500×2200
SC(B)14-1000/10	6	1205	6430	0.4	50	1510×1020×1110	820×820	1900×1500×1800	1900×1500×2200
SC(B)14-1250/10	6	1420	7610	0.4	51	1540×1020×1160	820×820	2000×1600×2000	2000×1600×2200
SC(B)14-1600/10	6	1665	9230	0.3	51	1650×1150×1230	820×1070	2000×1600×2000	2000×1600×2200
SC(B)14-2000/10	6	2075	11420	0.3	52	1730×1150×1330	1070×1070	2200×1600×2200	2200×1600×2200
SC(B)14-2500/10	6	2450	13540	0.3	53	1810×1150×1370	1070×1070	2200×1600×2200	2200×1600×2200
SC(B)14-1600/10	8	1665	10160	0.3	51	1650×1150×1190	820×1070	2000×1600×2000	2000×1600×2200
SC(B)14-2000/10	8	2075	12530	0.3	52	1730×1150×1300	1070×1070	2200×1600×2200	2200×1600×2200
SC(B)14-2500/10	8	2450	14830	0.3	53	1810×1150×1320	1070×1070	2200×1600×2200	2200×1600×2200

Note: The data given in this manual is for planning and selection purposes only. Final data may vary.



### SC(B)18-100~2500/10

HV: 10 (10.5,11,6.6,6.3,6)kV  
LV: 0.4kV

Vector Group: Dyn11, Yyn0  
Tapping Range: ±2×2.5%

Model	Uk %	PO (W)	Pk (75°) (W)	I0%	LPA(AN)dB	Gauge m x n (mm)	Transformer Dimension LxBxH (mm)	Enclosure Size (top outging line) (footing included)	Enclosure Size (side outging line) (footing included)
SC(B)18-100/10	4	230	1240	0.7	42	550×550	1050×750×790	1700×1400×1600	1700×1400×2200
SC(B)18-125/10	4	270	1450	0.7	42	550×550	1050×750×830	1700×1400×1600	1700×1400×2200
SC(B)18-150/10	4	310	1670	0.7	42	550×550	1100×750×880	1700×1400×1600	1700×1400×2200
SC(B)18-200/10	4	360	1990	0.7	43	550×550	1090×750×900	1700×1400×1600	1700×1400×2200
SC(B)18-250/10	4	415	2170	0.7	43	660×660	1150×860×940	1700×1400×1600	1700×1400×2200
SC(B)18-315/10	4	510	2730	0.7	45	660×660	1180×860×970	1700×1400×1600	1700×1400×2200
SC(B)18-400/10	4	570	3140	0.7	45	660×660	1290×860×990	1700×1400×1600	1700×1400×2200
SC(B)18-500/10	4	670	3830	0.6	46	660×660	1260×860×1030	1700×1400×1600	1700×1400×2200
SC(B)18-630/10	4	775	4610	0.6	46	820×660	1300×860×1120	1900×1500×1800	1900×1500×2200
SC(B)18-630/10	6	750	4690	0.6	46	820×660	1390×860×1060	1900×1500×1800	1900×1500×2200
SC(B)18-800/10	6	875	5470	0.4	49	820×820	1450×1020×1070	1900×1500×1800	1900×1500×2200
SC(B)18-1000/10	6	1020	6430	0.4	50	820×820	1510×1020×1110	1900×1500×1800	1900×1500×2200
SC(B)18-1250/10	6	1205	7610	0.4	51	820×820	1540×1020×1160	2000×1600×2000	2000×1600×2200
SC(B)18-1600/10	6	1415	9230	0.3	51	820×1070	1650×1150×1230	2000×1600×2000	2000×1600×2200
SC(B)18-2000/10	6	1760	11420	0.3	52	1070×1070	1730×1150×1330	2200×1600×2200	2200×1600×2200
SC(B)18-2500/10	6	2080	13540	0.3	53	1070×1070	1810×1150×1370	2200×1600×2200	2200×1600×2200
SC(B)18-1600/10	8	1415	10160	0.3	51	820×1070	1650×1150×1190	2000×1600×2000	2000×1600×2200
SC(B)18-2000/10	8	1760	12530	0.3	52	1070×1070	1730×1150×1300	2200×1600×2200	2200×1600×2200
SC(B)18-2500/10	8	2080	14830	0.3	53	1070×1070	1810×1150×1320	2200×1600×2200	2200×1600×2200

### SC(B)10-200~2500/20

HV: 20 (22, 24)kV  
LV: 0.4kV

Vector Group: Dyn11, Yyn0  
Insulation Level: LI 125 AC 50 / LI AC 3

Tapping Range: ±2×2.5%

Model	Uk %	PO (W)	Pk (75°) (W)	I0%	LPA(AN)dB	Gauge m x n (mm)	Transformer Dimension LxBxH (mm)	Enclosure Dimension (footing included)
SC ( B ) 10-200/20	6	730	2565	1.0	47	660×660	1425×860×1184	1650×1400×1660
SC ( B ) 10-250/20	6	840	2985	1.0	47	820×660	1450×860×1317	2000×1400×1660
SC ( B ) 10-315/20	6	970	3560	0.9	48	820×820	1460×1020×1339	2000×1400×1865
SC ( B ) 10-400/20	6	1150	4225	0.8	48	820×820	1490×1020×1344	2100×1450×1965
SC ( B ) 10-500/20	6	1350	5055	0.8	50	820×820	1580×1070×1471	2100×1450×1965
SC ( B ) 10-630/20	6	1530	5970	0.7	50	820×820	1580×1070×1616	2200×1500×2065
SC ( B ) 10-800/20	6	1750	7210	0.6	51	820×820	1580×1070×1681	2300×1550×2065
SC ( B ) 10-1000/20	6	2070	8540	0.5	52	820×820	1700×1070×1536	2300×1650×2165
SC ( B ) 10-1250/20	6	2380	10040	0.5	52	1070×1070	1760×1270×1621	2400×1700×2300
SC ( B ) 10-1600/20	6	2790	12050	0.4	53	1070×1070	1900×1270×1781	2500×1800×2400
SC ( B ) 10-2000/20	6	3240	14230	0.4	53	1070×1070	2060×1270×2081	2700×1800×2500
SC ( B ) 10-2500/20	6	3870	16850	0.3	54	1070×1070	2260×1270×2016	2800×1900×2700

Note: The data given in this manual is for planning and selection purposes only. Final data may vary.



**SC(B) 10-250~2500/35**

HV: 35(38.5, 37.5, 36.5, 33) kV      Vector Group: Dyn11, Yyn0  
 LV: 0.4kV      Tapping Range:  $\pm 2 \times 2.5\%$

Model	UK%	P0(W)	PK(W)75°	I0%	LPA(AN)dB	Gauge m x n (mm)	Transformer Dimension LxBxH (mm)	Enclosure Dimension LxBxH (mm)
SC10-250/35	6	990	3250	0.73	52	820×820	1470×1000×1591	2300×1700×2000
SC10-315/35	6	1180	3900	0.6	52	820×820	1580×1100×1870	2600×1800×2300
SC10-400/35	6	1380	4700	1.6	52	820×820	1790×1100×1700	2600×1800×2100
SCB10-500/35	6	1620	5700	0.43	52	820×820	1620×1100×1930	2420×1800×2300
SCB10-630/35	6	1860	6600	0.36	52	820×820	1720×1100×1970	2520×1900×2350
SCB10-800/35	6	2160	7800	0.63	53	820×820	1840×1200×2000	2650×1900×2350
SCB10-1000/35	6	2430	9100	0.47	53	1070×820	2070×1200×1980	2870×1900×2350
SCB10-1250/35	6	2840	11000	0.4	53	1070×1070	2180×1400×2000	2980×2000×2450
SCB10-1600/35	6	3240	13400	0.3	55	1070×1070	2000×1300×2270	2800×2000×2650
SCB10-2000/35	6	3825	15928	0.28	55	1070×1070	2130×1300×2340	3200×2200×2700
SCB10-2500/35	6	4460	18641	0.52	55	1070×1070	2240×1400×2370	3000×2000×2700

Note: The data given in this manual is for planning and selection purposes only. Final data may vary.

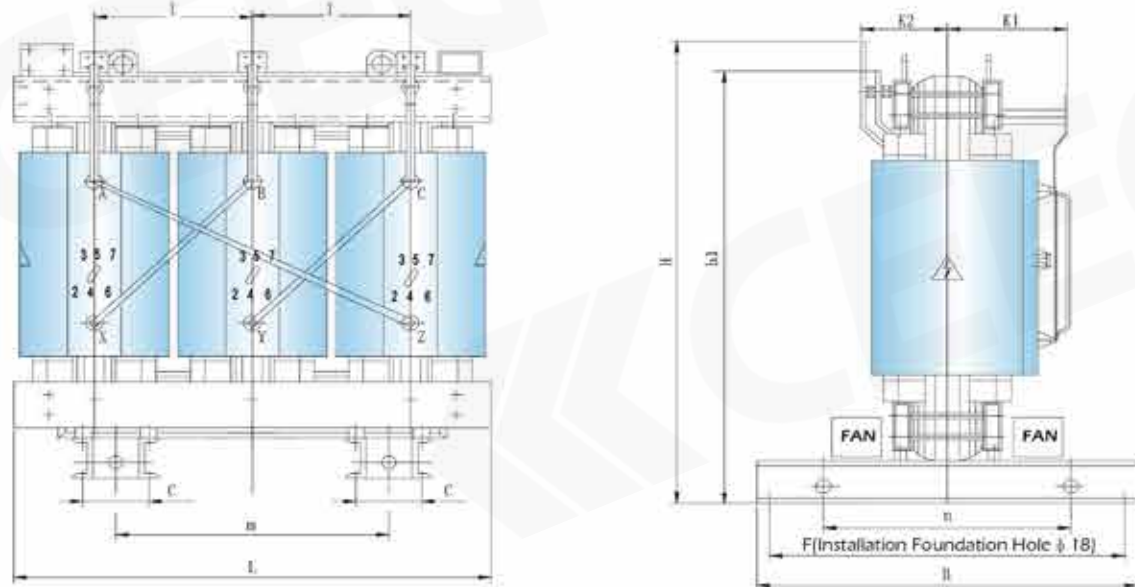

LV Terminal Busbar

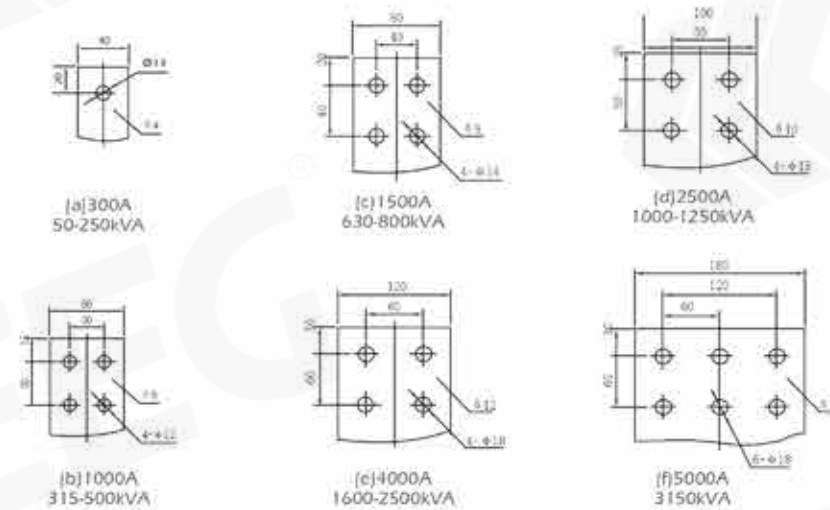



### SC11-800~25000/35

HV: 35 (38.5, 37.5, 36.5, 33)kV  
 LV: 10.5 (11, 6.0, 6.3, 3.15)kV

Vector Group: Yd11, YNd11, Dyn11  
 Tapping Range:  $\pm 2 \times 2.5\%$

Model	UK%	P0(W)	PK(W)75°	I0%	LPA(AN)dB	Gauge m x n (mm)	Transformer Dimension LxBxH (mm)
SC11-800/35	6	2025	9400	0.6	50	1475×820	2210×1070×1680
SC11-1000/35	6	2400	10900	0.6	50	1475×820	2280×1070×1720
SC11-1250/35	6	2815	12900	0.5	50	1475×1070	2380×1200×1810
SC11-1600/35	6	3320	15400	0.5	50	1475×1070	2405×1400×2285
SC11-2000/35	7	3805	18200	0.45	52	1475×1070	2530×1400×2330
SC11-2500/35	7	4370	21800	0.45	52	1475×1070	2650×1400×2345
SC11-3150/35	8	5425	24500	0.4	53	2040×1475	2980×1400×2360
SC11-4000/35	8	6315	29400	0.4	53	2040×1475	3120×1600×2410
SC11-5000/35	8	7530	34900	0.35	54	2040×1475	3170×1600×2460
SC11-6300/35	8	8910	40800	0.35	54	2040×1475	3250×1800×2565
SC11-8000/35	9	10170	46000	0.3	56	2040×1475	3390×1800×2675
SC11-10000/35	9	11610	55500	0.25	60	2040×1475	3570×2000×2765
SC11-12500/35	9	14130	64600	0.2	60	2040×1475	3770×2000×2885
SC11-16000/35	9	17370	76000	0.2	62	2300×1475	4200×2000×3150
SC11-20000/35	10	20610	85500	0.2	62	2580×1475	4610×2000×3460
SC11-25000/35	10	24390	101000	0.2	64	2580×1475	4810×2000×3490

Note: The data given in this manual is for planning and selection purposes only. Final data may vary.

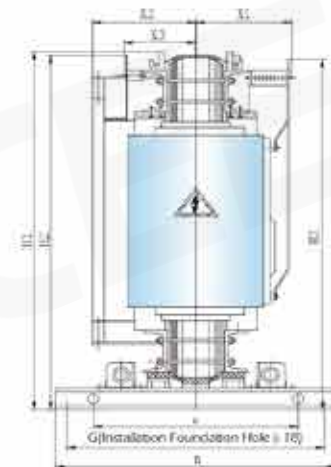
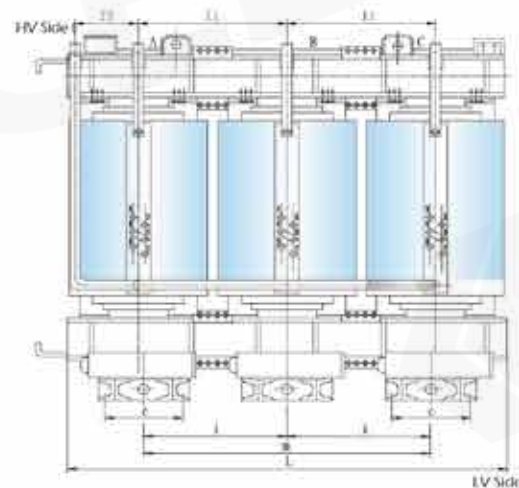

LV Terminal Busbar

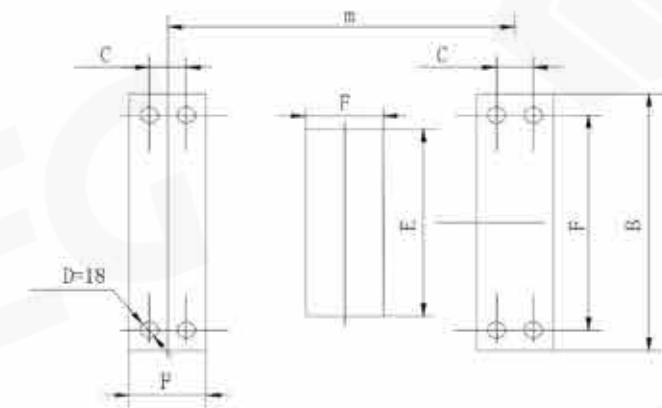



ZQSC series 10kV 800~3300kVA Traction Rectifier Transformer

Model	UK%	P0(W)	PK(W)	I0%	LPA(AN)dB	Dimension
ZQSC-800/10	6.2	1794	5959	0.33	54	2250×1400×2300
ZQSC-1000/10	6.2	1882	7360	0.28	54	2250×1450×2400
ZQSC-1250/10	6.2	2729	8615	0.32	54	2350×1500×2500
ZQSC-1600/10	6.2	3300	8864	0.27	55	2600×1600×2500
ZQSC-1800/10	6.5	3397	10600	0.25	55	2600×1600×2550
ZQSC-2000/10	6.8	3574	11094	0.25	55	2650×1700×2600
ZQSC-2500/10	8	3943	13548	0.21	56	2700×1750×2700
ZQSC-2750/10	8	4023	13917	0.2	56	2800×1750×2800
ZQSC-3300/10	8	4070	15245	0.24	57	2800×1800×2900

ZQSCB series 35kV 1600~4400kVA Traction Rectifier Transformer

Model	UK%	P0(W)	PK(W)	I0%	LPA(AN)dB	Dimension
ZQSCB-1600/35	8	3600	15400	0.9	53	2280×1300×2420
ZQSCB-2000/35	8	4200	18000	0.9	53	2340×1300×2595
ZQSCB-2500/35	8	4800	21000	0.9	54	2500×1400×2620
ZQSCB-2750/35	8	4900	22000	0.9	54	2500×1400×2750
ZQSCB-3000/35	8	5700	23000	0.8	54	2620×1600×2625
ZQSCB-3300/35	8	6200	25000	0.8	55	2590×1600×2745
ZQSCB-4000/35	8	7000	29000	0.8	55	2660×1800×2770
ZQSCB-4400/35	8	7500	31000	0.7	56	2730×1800×2795

Note: The data given in this manual is for planning and selection purposes only. Final data may vary.

20kV 800~20000kVA Non-excitation Voltage Regulating Power Transformer

Capacity kVA	Voltage Ratio			Vector Group	P0(kW)	PK(kW)		I0%	Uk%	LPA(AN)dB
	HV(kV)	Tapping Range%	LV(kV)			75°	100°			
800					2300	7640	8750	1.5	6	52
1000					2500	9690	11100	1.5	6	52
1250					3100	11790	13500	1.3	6	52
1600			3		3630	13800	15800	1.3	6	54
2000	13.8		3.15		4240	15800	18100	1.1	7	55
2500	15.75		6	Yd11	4850	18160	20800	1.1	7	55
3150	18		6.3	YNd11	6160	21830	25000	0.9	8	56
4000	20		6.6		6930	25320	29000	0.9	8	56
5000	22		10		7810	28990	33200	0.7	8	58
6300	24		10.5		9980	33960	38900	0.7	8	60
8000			11		12280	38420	44000	0.6	8	60
10000					14410	43650	50000	0.6	8	62
12500					18150	47150	54000	0.6	8	63
16000					22660	53260	61000	0.5	8	64
20000					27170	62430	71500	0.5	8	65

Note: According to the requirements, the high-voltage tapping range of urban transformer can be  $\pm 2 \times 2.5\%$ , The data given in this manual is for planning and selection purposes only. Final data may vary.



# SPECIAL APPLICATIONS

## • Traction Rectifier Transformer

The rated capacity is 800 – 4400kva, the voltage level is 10 and 35kV, and the number of rectified pulses is 12 pulses and 24 pulses. Among them, the harmonic pollution of 24 pulse rectifier circuit to power grid is 50% lower than that of 12 pulse rectifier circuit, so the filter device can be omitted. It is suitable for the power supply system of urban subway and rail transit.

## • Excitation Rectifier Transformer

Rated capacity 315 ~ 3000 × 3KVA, with voltage levels of 10, 13.8, 15.75, 20 and 22kv. It usually adopts single-phase structure, high-voltage isolated phase enclosed bus incoming line and shielding between high-voltage coils. It is suitable for the static excitation system of hydropower plant and thermal power plant.

## • General Rectifier Transformer

The rated capacity is 315 – 4000kva, and the voltage level is 10 and 35kV. It is suitable for the rectifier system of general industrial and mining enterprises.

## • H-bridge Rectifier Transformer

The rated capacity is 315 – 2500kVA, the voltage level is 3 and 6kV, and each set has 3 – 9 windings per phase. Two can be combined to form H-bridge rectifier through phase-shifting connection. It is suitable for AC-AC Variable frequency power supply system of motor.

## • Transformers for marine and oil production platforms

The rated capacity is 30 – 10000kva and the voltage class is 0.38 and 35kV. It has passed the certification of China Classification Society and obtained the marine product type approval certificate of China Classification Society. It is suitable for marine and oil production platform power supply system.

## • Transformers for nuclear power plants

The rated capacity is 1000 – 1250kva and the voltage level is 10kV. It has passed the experimental examination and certification of dry-type transformer for IE nuclear power station. It is suitable for nuclear island class ie electrical system for nuclear power plant and nuclear reactor equipment.

## • Transformer for Electrified Railway

The rated capacity is 20 – 315KVA, the voltage level is 27.5kV, and the connection groups are Dyn11, Li0 and iyn0 (two-phase to three-phase). It can be used for the auxiliary power system of traction substation, switching post, at post and section post of electrified railway.

## • Dual Voltage Switching Transformer

The rated capacity is 30 – 2500kVA and the voltage grade is 6 and 10kV. The voltage (6kV and 10kV) can be transformed by changing the connection group or the connection mode of exchange winding section. It is suitable for power supply systems with different voltages.

**Other special-purpose dry-type transformers produced by our company are not explained one by one. If you need other special-purpose dry-type transformers, please contact us.**



# USE & INSTALLATION

# 8

## Service Conditions

1. The installation site shall not be flooded by water, the altitude shall not exceed 1000m, and the ambient temperature shall not be higher than 40 °C. The relative humidity is 100%, and the environment is 40 °C to - 25 °C (- 25 °C requires on-load tap changer and temperature controller).

2. The installation site shall be clean, free of conductive dust and corrosive gas, and have good ventilation or artificial ventilation conditions.

3. During product installation, it shall be 300mm away from walls and other obstacles, and there shall be a distance of 300mm between adjacent transformers. For distribution boxes and other places with limited installation space, the above distance can be adjusted appropriately.

## Packaging & Transportation

1. The products can be partially disassembled and transported (such as on-load tap changer, temperature controller, air cooling device, enclosure, etc. can be packaged separately) or packed as one piece in packaging boxes for transportation.

2. During the lifting process of the package, ropes shall be hung on sleepers at the four corners at the bottom of the package. Special lifting devices should be used to lift the products after the package is opened. It can be lifted 100 mm-150 mm above the ground first, and then formally lifted after there is no abnormality.

3. During transportation, there shall be no upward and downward slope greater than 15 ° on the road. In order to ensure that the vehicle can bear the load evenly, the product center of gravity shall be located on the vertical centerline of the vehicle during loading. In order to prevent displacement and rollover during transportation, the long axis direction of the product shall be consistent with the transportation direction, and the product shall be firmly bound on the vehicle.

4. During transportation, there shall be no upward and downward slope greater than 15 ° on the road. In order to ensure that the vehicle can bear the load evenly, the product center of gravity shall be located on the vertical centerline of the vehicle during loading. In order to prevent displacement and rollover during transportation, the long axis direction of the product shall be consistent with the transportation direction, and the product shall be firmly bound on the vehicle.



## Visual inspection before installation

1. After opening the package, remove the protective device and check the external conditions, especially paying attention to the mechanical integrity of the coil and iron core, the compression degree of the coil and iron core, and the bolt fastening at the connection.

2. After inspection, all fasteners, coils and iron core pressing parts must be tightened in turn without any looseness.

3. Use dry compressed air or clean cloth to clean the dust and dirt on the product.

4. When the storage time is long and there are water droplets or condensation on the transformer surface, it shall be dried until the insulation resistance of the coil is qualified.



## Inspection before operation

1. Measure the DC resistance of high and low voltage windings

(whether the data is consistent with the data given in the factory test certificate).

2. Check the grounding of the iron core to see whether the grounding is reliable and whether foreign matters are overlapping.

3. Test insulation resistance



## Energizing

1. Before putting into operation, the transformer shall be put into trial operation under no-load, and the protection system shall be checked and adjusted after 3 times of impulse closing.

2. When the product leaves the factory, the tap positions of voltage regulation at the high-voltage side are connected according to the rated position. Voltage adjustment is required during operation. Corresponding tap connection can be carried out according to the decomposition voltage indicated on the nameplate (when there is no excitation voltage regulation), and it must be carried out when the transformer power supply is cut off.





**REFERENCES &  
QUALIFICATIONS**



- |    |    |  |                                       |
|----|----|--|---------------------------------------|
| 01 | 02 | 01. Beijing Olympic Wukesong Sports Center                       | 02. Beijing Olympic Badminton Stadium |
| 03 | 04 | 03. Beijing Olympic Badminton Stadium                            | 04. Nanjing Metro Line 4              |
| 05 |    | 05. Huangpu River Crossing Tunnel Project of Shanghai World Expo |                                       |





Rio Tinto project in Australia



Shenzhou V manned space project



Philippine cement plant



Beijing South Railway Station



Guangdong Hong Kong Sea crossing bridge



Subic Bay solar power station in the Philippines



Beijing Capital Airport



Shanghai Disney



CHINA INTERNATIONAL IMPORT EXPO



China Mobile



China Unicom



China Telecom



Wuxi Metro



Sinopec Shengli Construction Engineering Co., Ltd



CNOOC ZOJE Petrochemical Co., Ltd



Beijing Electric Power Company



China Shipbuilding Industry Co., Ltd



Liaoning Electric Power Company



SEPCOIII Electric Power Construction Co., Ltd



Shanxi Electric Power Company



Tianjing Electric Power Company



China Gezhouba Group Corporation



SIEMENS China



China Nuclear Power Engineering Co., Ltd



China National Nuclear Corporation 404 Co., Ltd



Datong Coal Mine Group



BaoSteel



Capital Aerospace Machinery Co., Ltd



China Railway 12th Bureau Electrification Engineering Co., Ltd



